

TNT SERIES

WATER CONDITIONERS



For Commercial & Industrial Applications

Apartment Buildings
Boiler Water Treatment
Car Washes
Commercial Buildings
Condominiums
Factories
Hospitals

Laundries
Mobile Home Parks
Motels and Hotels
Nursing and Rest Homes
Office Buildings
Restaurants
Schools

Hellenbrand[®]

Hellenbrand Means Quality and Reliability

Since 1967, Hellenbrand Water Conditioners, Inc. has provided water solutions to the water treatment industry in the U.S. and around the world. We have developed a complete line of high quality products. An excellent example of this, is the Hellenbrand TNT Series Conditioners.

TNT Series Conditioners use a flanged top-mounted or optional side-mounted adapter, three-inch NPT inlet and outlet solid brass control valve with a motor-driven, time-tested, hydraulically-balanced piston with a seal and spacer concept to pilot service flow not dependent on water pressure. No diaphragms to rupture or false transfer. It will provide up to 170 gpm hard water by-pass during regeneration, or you may have the optional "no hard water by-pass piston" for twin or multiple systems. These high service flow rates, the simplified alternating and multiple lockout systems, eliminate the need for diaphragms, solenoids and stagers. The five cycle TNT controller is available with either downflow (co-current) or upflow (counter-current) brining, with easy adjustable cycle times. The TNT Series offers you a choice of mechanical or microprocessor controlled meter demand systems, with two-inch or three-inch meter turbines. All systems are factory-wired and tested electrically to assure easy installation and correct operation.

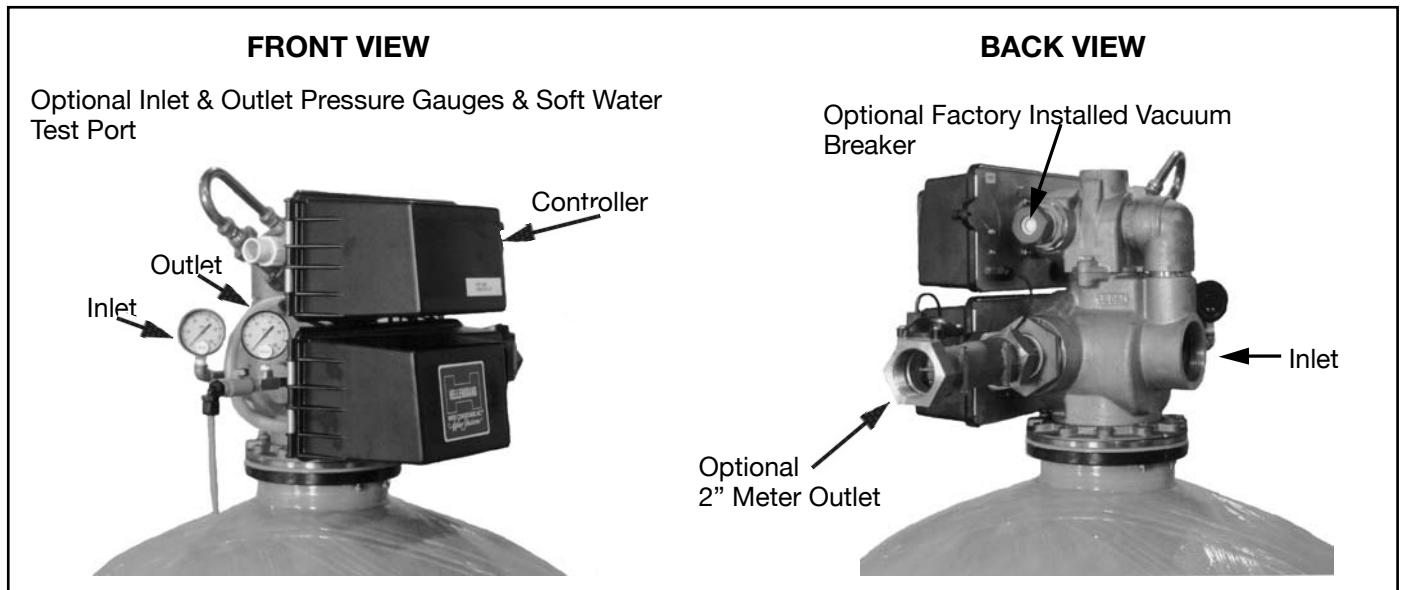

TNT Series Control Valve -Three Inch Inlet/Outlet

1. Stainless Steel Backplate will not rust or corrode.
2. Factory provided Drain Line Flow Control maintains accurate backwash rates.
3. Three-Inch NPT Inlet & Outlet Connections.
4. Solid Brass Valve assures durability and long life.
5. Hydraulically-balanced Piston, Seal, and Spacers. Lower service piston is available with or without hard water by-pass. Non-sticking Teflon-coated Piston allows foreign particles to pass through without damaging the unit.
6. Upper Piston pilots the regeneration steps of backwash, brine and slow rinse, fast rinse, and brine tank refill.
7. Separate "Time-fill" Brining with accurate flow controls allows automatic brine tank refill. Brine Tank Refill Rates are easily adjustable on the cycle programmer. No need to worry about adjusting float valves or repositioning brine plugs for salt measurements.
8. Heavy-duty Drive Motor receives signal from timer to efficiently direct water flow during regeneration. Piston shifts smoothly and quietly regardless of water pressure.
9. Lower Heavy-duty Drive Motor receives signal from upper drive motor to direct the service piston into position. Piston shifts smoothly and quietly regardless of water pressure.
10. TNT Series Timer provides fully automatic, dependable timing for regeneration. The Cycle Programmer regulates all regeneration cycles which are easily adjustable. For manual regeneration start, simply turn the service indicator clockwise.

TNT Electronic Controller Options

SYSTEM FEATURES for all configurations - XT, NXT or NXT-14

- 2x16 character backlit LCD display
- Auxiliary inputs and outputs
 - Remote signal start
 - Remote lockout input
 - Programmable relay output
 - Chemical feed pump proportional output
- Easy installation, plug-in wiring harness (CAT3 or better)
- Simple on site programming
- Three programming modes
 - User mode
 - Master programming
 - Diagnostic
 - Current flow rate
 - Peak flow rate (can be reset)
 - Totalizer (can be reset)
 - Hours between last two regenerations
 - Hours since last regenerations
 - Volume remaining (adjustable)
 - Valve addresses



XT Timer Features

- Single or twin parallel systems (no inter-unit communication)
- Regeneration options
 - Time clock delayed
 - Meter immediate
 - Meter delayed with fixed reserve
 - Meter delayed with variable reserve
 - Meter delayed with weekly reserve
 - Remote signal immediate
 - Remote signal delayed
 - Volume override immediate
 - Volume override delayed

NXT Timer Features

- Single or 2, 3, or 4 systems networked together
 - System 4 - single
 - System 5 - (2-4 units) meter on each unit w/lockout
 - System 6 - (2-4 units) one meter, series regeneration
 - System 7 - (2 units) one meter, alternating
 - System 9 - (2-4 units) meter on each unit, alternating, one unit in stand-by or regeneration, the others in service
- Regeneration options
 - Time clock delayed (System 4 only)
 - Meter delayed with fixed reserve (System 4 only)
 - Meter immediate (System 5,6,7 & 9)
 - Remote signal start (System 5,6,7 & 9)

NXT-14 Timer Features

- 2, 3 or 4 systems networked together
- Immediate regeneration only
- Progressive flow - demand regeneration. One or more units in service depending on flow rate requirement. Other units either in standby or regeneration. Only one unit can regenerate at a time.

Standard Electronic Meter Options:

Size	Flow Ranges	Accuracy
1" Meter	0.25 - 40 GPM	±3%
1.5" Meter	0.50 - 60 GPM	±5%
2" Meter	1.50 - 150 GPM	±5%

TNT Series

- A. MINERAL TANK: Poly Glass™ Composite tank with Polyethylene Inner Shell and Fiberglass Roving Manufactured to Operate at 150 psi. NSF Approved.
- B. DISTRIBUTOR SYSTEM: Three-Inch Hub & Lateral Distribution for Maximum Service Flow and Minimal Pressure Loss.
- C. MINERAL: High Capacity Ion Exchange Resin. Uniform and stable beads assure long life, high salt efficiency, and maximum hardness removal.
- D. UNDERBEDDING: Multi-Layered Gravel Underbedding assures full usage of mineral bed and allows for a smooth and constant water flow for service and regeneration.
- E. BRINE TANK: Rotationally Molded Polyethylene with Dust-tight cover.
- F. GRID PLATE: Grid plate allows for dry salt storage. Available in various sizes and heights.
- G. OPTIONAL SAFETY BRINE VALVE: Acts as a Secondary Shut-Off for Timed Brine and may be used as a Primary Shut-Off without Timed Brine.

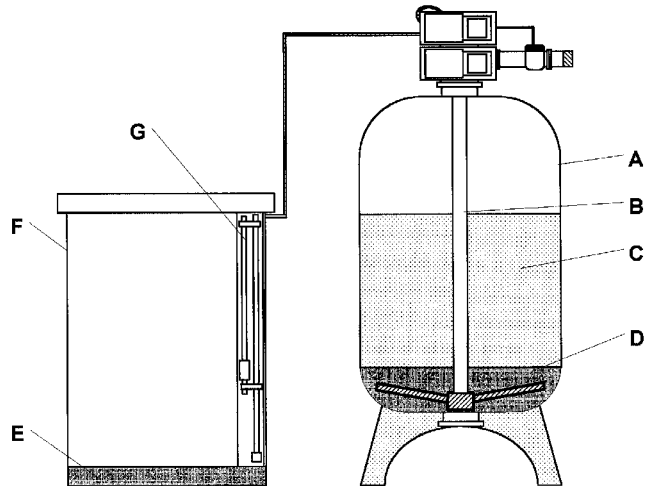

Note: Steel tanks optional

Typical Single Tank Installation

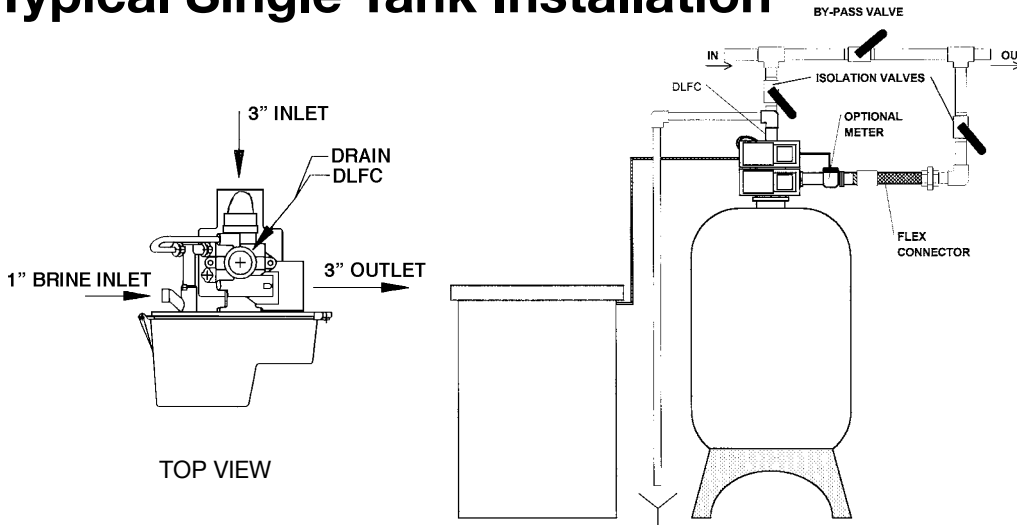

Note:

1. Optional stainless steel flex connectors are available for inlet and outlet connections. These are recommended on systems utilizing Polyglass composite tanks with rigid piping such as copper, galvanized, ect.
2. Union type connections are recommended on the inlet and outlet connections.

Twin Alternating Tank Installation

(Available with individual brine tanks as shown or with one twin brine tank.)

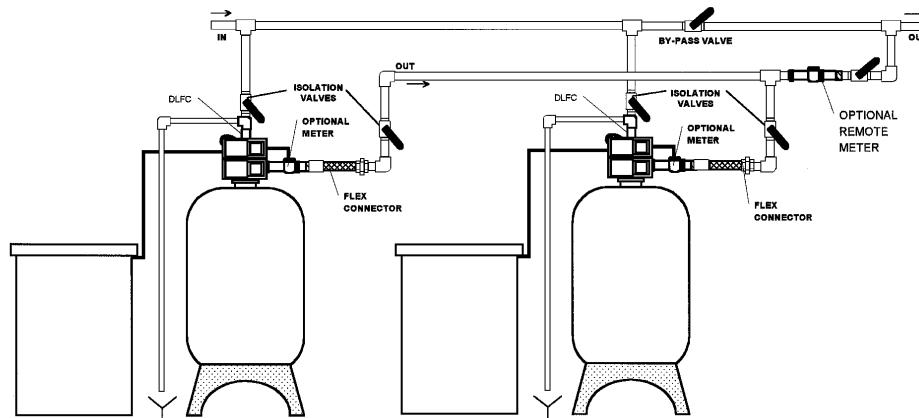

Note:

1. Optional stainless steel flex connectors are available for the inlet and outlet connection with each system and must be installed on systems utilizing Polyglass™ composite tanks with rigid piping in copper, galvanized...etc.
2. Union type connections are recommended on the inlet and outlet connections.

SideMount

Where ceiling heights may pose a restriction or a side-mounted configuration is preferred, TNT Series systems are available in this design configuration. Factory pre-piped and pressure tested, these system designs must be shipped either skid mounted or have face piping dis-assembled for shipment and re-assembled at the job site. Available with non-corrosive polyglass composite tanks or steel. Consult factory for details.

Skid mounted and factory pre-piped

Optional skid mounted system design configurations with or without factory interconnecting piping for twin or tri-plex system designs are available, in both top-mount or side-mount design configurations.

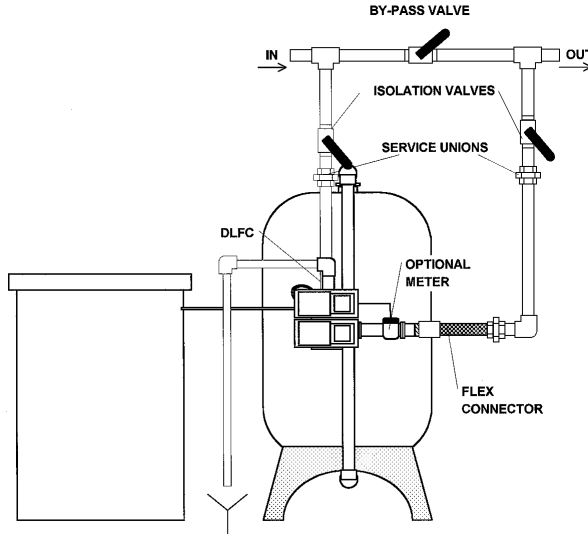

2" Meter

2" Meter and Flow/Pressure Loss Data

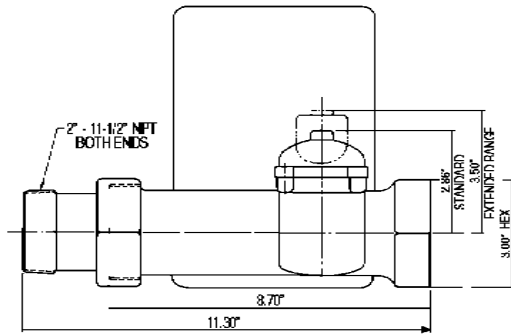

2" Brass Meter

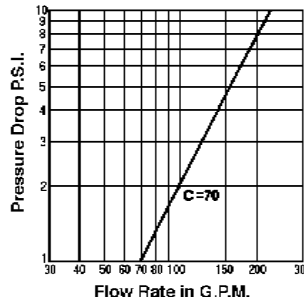

- Standard Range 1,250 Gal. Min. to 21,250 Gal. Max.
- Extended Range 6,250 Gal. Min. to 106,250 Gal. Max.

- Flow accuracy — ±5% from 3 to 150 GPM
- Dimensions & Flow Data are the same with NT Microprocessor

3" Meter

3" Meter and Flow/Pressure Loss Data

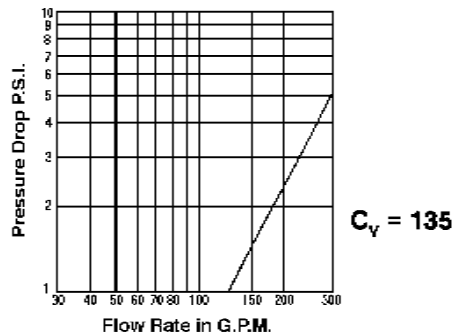
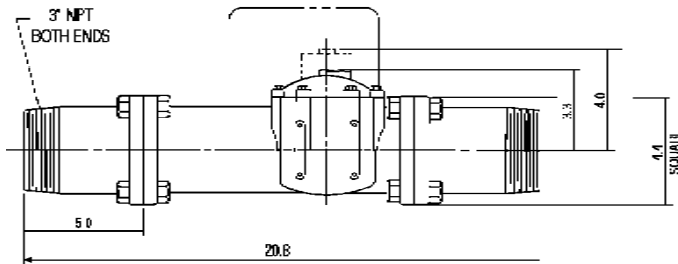

- Standard Range 3,750 Gal. Min. to 63,750 Gal. Max.
- Extended Range 18,750 Gal. Min. to 318,750 Gal. Max.
- Other meters available, consult factory

- Flow accuracy — ±5% from 7 to 300 GPM
- Dimensions & Flow Data are the same with NT Microprocessor

TNT Service Rates & Pressure Drop Charts

TNT-300 3" Service Rates & Pressure Drop Chart

11/92

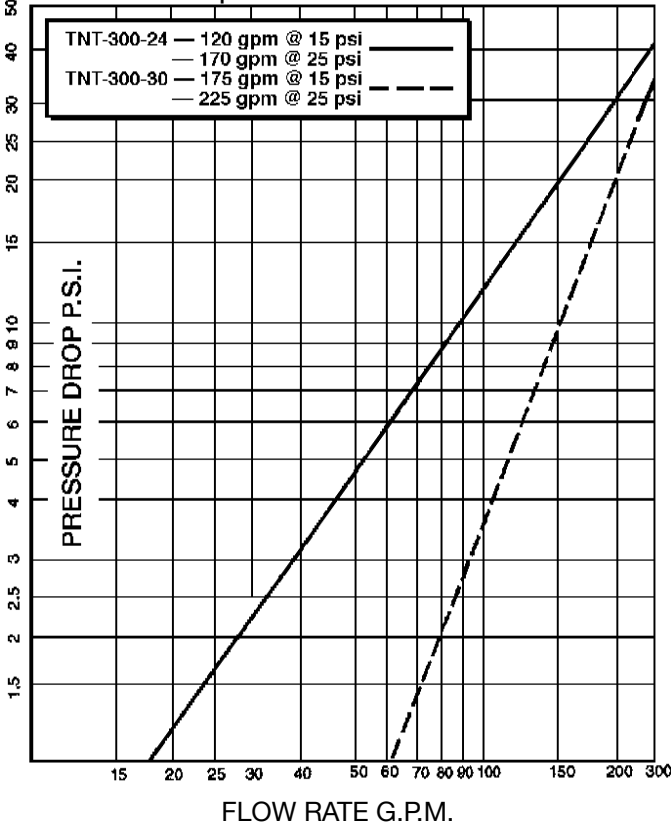

TNT-450 3" Service Rates & Pressure Drop Chart

11/92

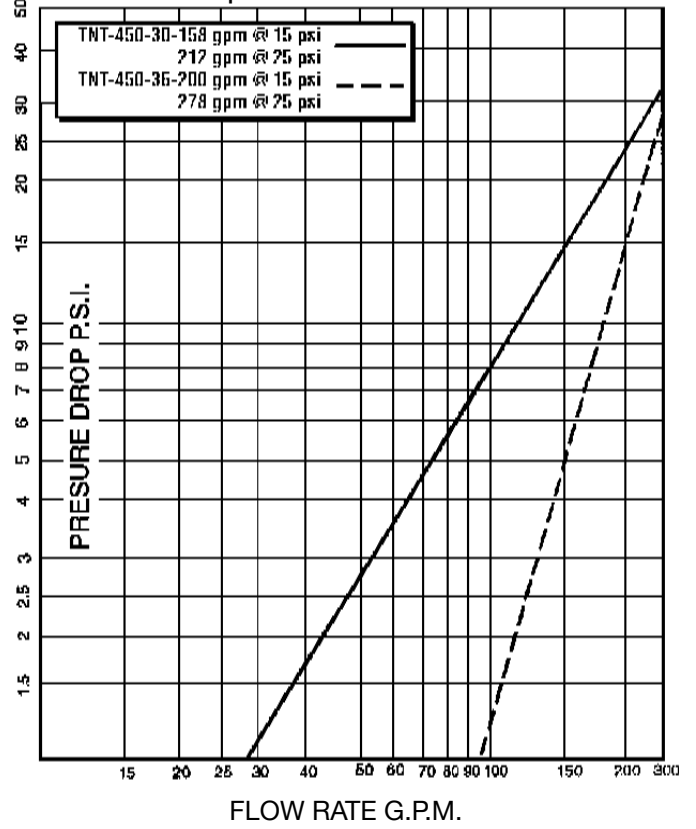

TNT-600 3" Service Rates & Pressure Drop Chart

11/92

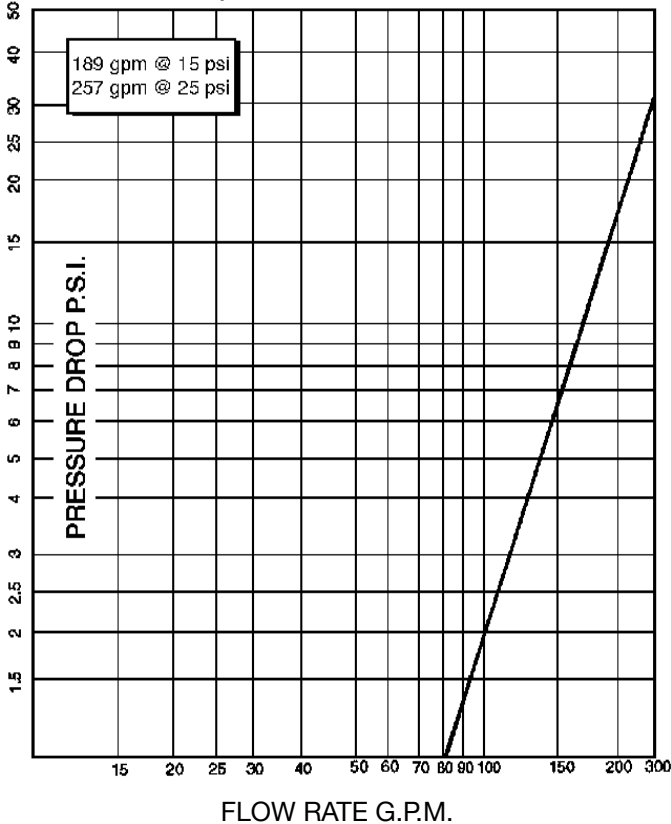

TNT-750 3" Service Rates & Pressure Drop Chart

11/92

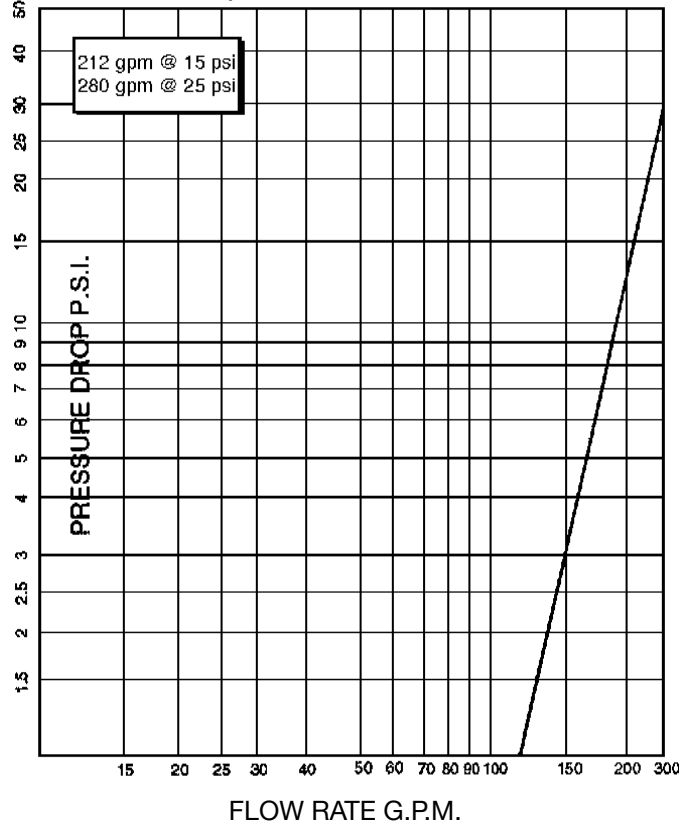

Pressure Drop Charts

TNT-900-48 3" Service Rates
& Pressure Drop Chart

11/92

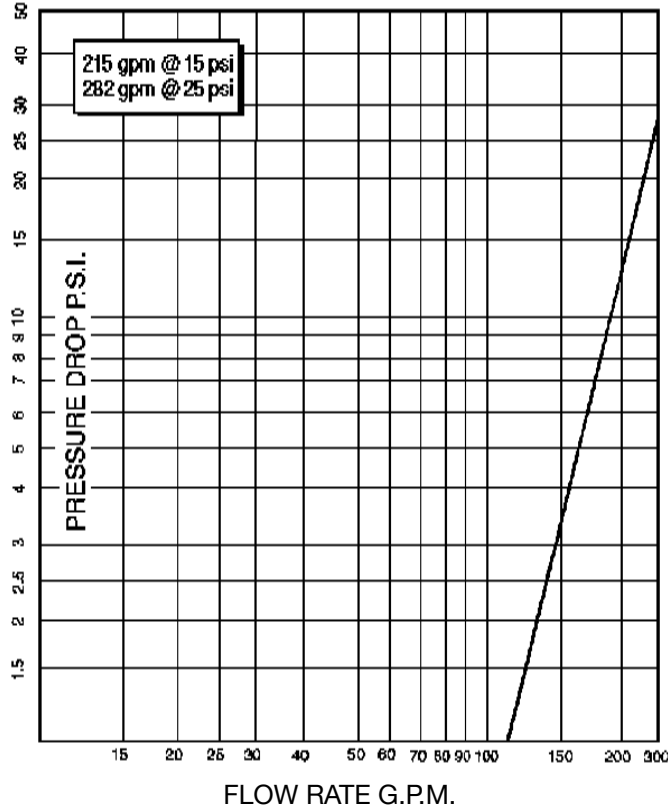

TNT-1200 3" Service Rates
& Pressure Drop Chart

11/92

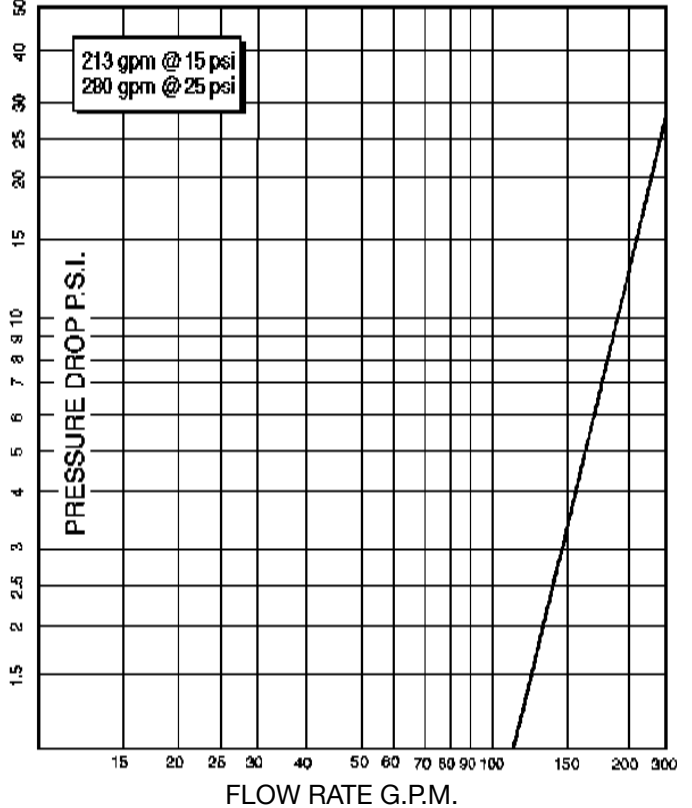

Commercial/Industrial Tanks



High Grade Polyethylene Tank Liner

- Fiber-free inner surface suitable for all standard water treatment applications.
- Offers wide chemical resistance; not adversely affected by regenerating chemicals.

Strong, Filament Wound Outer Laminate

- Continuous strands of fiberglass reinforced with high strength epoxy resin.
- Rustproof and corrosion-resistant

Operating Parameters

- Maximum operating pressure: 150 PSI (10.2 BAR)
- Maximum operating temperature: 120°F (49°C)

Industry Approved

- Tanks designed and tested to meet industry standards, ensuring top field performance:
 - NSF® Standard 44

Warranty

- All commercial/light industrial tanks are backed by an exclusive limited manufacturer's warranty:
 - Sizes 24" through 48": 5 year limited warranty

TNT Physical Specifications

Mineral tank sizes shown are with composit/FRP tanks.

MODEL	PIPE SIZE (INCHES)	MINERAL TANK (INCHES)	RECOMMENDED BRINE TANK		MINERAL TANK GRAVEL UNDERBEDDING		APPROXIMATE SHIPPING WEIGHT	
			SIZE (INCHES)	SALT STORAGE (LBS)	1/4" X 1/8"	#20	SINGLE	TWIN
TNT-300-24	3	24 X 72	30 X 50	1,110	0	150	1085	2145
TNT-300-30	3	30 X 72	30 X 50	1,110	200	75	1160	2295
TNT-450-30	3	30 X 72	39 X 48	2,030	200	75	1600	3120
TNT-450-36	3	36 X 72	39 X 48	2030	300	150	1835	3590
TNT-600	3	36 X 72	39 X 48	1,640	300	150	2115	4135
TNT-750	3	42 X 72	42 X 60	2,580	500	175	3475	6325
TNT-900	3	42 X 72	50 X 60	4,130	500	175	4280	8560
TNT-1200	3	48 X 72	50 X 60	3,495	700	200	4800	8760

TNT Capacity Ratings

MODEL	RESIN CU.FT.	RATED CAPACITY			FLOW RATES (gpm)		BKW GPM
		LOW SALT GRAINS/LBS	MEDIUM SALT GRAINS/LBS	HIGH SALT GRAINS/LBS	15 PSI	25 PSI	
TNT-300-24	10	190,000/60	280,000/100	320,000/150	120	170	12
TNT-300-30	10	190,000/60	280,000/100	320,000/150	175	225	20
TNT-450-30	15	285,000/90	420,000/150	480,000/225	158	212	20
TNT-450-36	15	285,000/90	420,000/150	480,000/225	200	278	30
TNT-600	20	380,000/120	560,000/200	640,000/300	189	257	30
TNT-750	25	475,000/150	700,000/250	800,000/375	212	280	40
TNT-900	30	570,000/180	840,000/300	960,000/450	215	282	40
TNT-1200	40	760,000/240	1,120,000/400	1,280,000/600	213	280	50

1. Steel tank design configurations available up through 60" tank diameters. Consult factory for details.

OPERATING CONDITIONS

1. Water Pressure 30 - 100 psi.
2. Water temperature is not to exceed 110°F and the unit cannot be subject to freezing conditions. Consult factory for higher water temperature applications.
3. Limit of 2 ppm of Ferrous Iron. Add 3 grains per gallon of hardness for each ppm of iron present.
4. Flex connectors and vacuum breakers are required when using the PolyGlass Composite mineral tanks.
5. Backwash flow rates are calculated at 4 gpm per sq. ft. of bed area and rounded off based on 50°F water temperature.
6. Refer to Hellenbrand Bulletin 2050 "Flow Rates and Soft Water Quality (Hardness Leakage) if your application requires that levels of hardness leakage do not exceed "x".

TNT Series Fiberglass Dimensions with Six-Inch Flange Opening

MODEL	HEIGHT		INLET/OUTLET HEIGHTS		SUGG. WIDTH	
	TOP MOUNT HT*	SIDE MOUNT HS**	TOP MOUNT IT	SIDE MOUNT IS	SINGLE	TWIN
TNT-300-24	101	87.5	82.5	51	62	99
TNT-300-30	101	87.5	80	51	68	108
TNT-450-30	112	96.5	80	51	83	117
TNT-450-36	112	97	81	51	83	129
TNT-600-36	112	97	81	51	83	129
TNT-750-42	113	104.5	92	51	92	144
TNT-900	113	104.5	92	51	92	144
TNT-1200-48	116	103	93	51	106	164

All dimensions ±1" and are subject to change without notice. Use as reference only.

*Allow additional 12" for resin filling on HT dimension.

**Allow additional 18" for resin filling on HS dimension.

Call factory for optional tank & dimensional configurations.

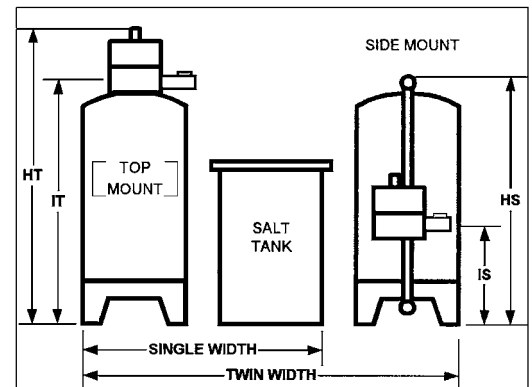

Product Improvement designs are subject to change without notice.



HELLENBRAND, INC.
1-800-626-1417
www.hellenbrand.com

DEALER NAME:

