



CONSUMER'S FILTER MANUAL

PROMATE 6.0 IRON CURTAIN JUNIOR



Franklin Water Treatment, LLC
hellenbrand.com

This owner’s manual is designed to assist owners with the operation, maintenance and installation of your new water filter. It is our sincere hope that this manual is clear, concise and helpful. Detailed instructions on general operating conditions, pre-installation and installation instructions, start-up, and meter programming are included. We have included a troubleshooting guide, service instructions and parts diagrams to assist future needs.

In the event that you need professional assistance for servicing your water filter, please contact the dealer who installed this system.

TABLE OF CONTENTS

General Specifications.....	3
Pre-Installation Check List.....	4
Bypass Valve Operation	4
Installation Instructions.....	5
Startup Instructions.....	6
Operating Conditions.....	6
Specifications	6
Programming, Displays/Settings	7
Regeneration Modes	8
Filter Disinfection	8
Set Time of Day	9
Recommended Maintenance.....	9
Parts Diagrams.....	10
Trouble Shooting	11
Warranty	12

Dealer Name _____	Phone _____
Address _____	Email _____

JOB SPECIFICATION SHEET

MODEL NO. _____

*WATER TEST AT TIME OF INSTALLATION

_____ Iron (ppm)	_____ Hydrogen Sulfide	_____ Manganese
_____ pH	_____ Chlorine	_____ Bromide
_____ TDS	_____ Tannins	_____ Other _____

Note: If continuous Chlorine or Ozone is added to the influent water before the filter system the influent water should be tested for the presence of Bromide. If detected, bromide must be removed prior to the addition of ozone or chlorine.

*SIZING INFORMATION

All Water is Filtered Except:

_____ Rear Hose Bib _____ Front Hose Bib _____ Kitchen Cold _____ Toilets _____ All Cold
_____ Other _____

*INSTALLATION DATE _____

*SERIAL NUMBER _____

NOTES _____

GENERAL SPECIFICATIONS

OPERATING PRESSURES

Minimum/Maximum 30 psi-100 psi

OPERATING TEMPERATURES

Minimum/Maximum 40° - 110° F

METER

Accuracy ±5%

Flow Rate Range 0.25 - 27 GPM

Gallon Range 20 - 50,000

DIMENSIONS

Drain Line 3/4" or 1" NPT

Regenerant Line 3/8" Poly Tube

ELECTRICAL CURRENT DRAW AND VOLTAGE 0.5A 110v

Compatible with the following regenerants or chemicals: Sodium chloride, potassium permanganate, sodium bisulfite, sodium hydroxide, hydroxide, hydrochloric acid, chlorine and chloramines.

PRE-INSTALLATION CHECK LIST

(All electrical & plumbing should be done in accordance to all local codes)

Water Pressure: A minimum of 30 pounds of water pressure (psi) is required for regeneration. Maximum pressure 100 psi.

Water Quality: On rural water supplies there is often a problem with sand or sediment in the water. (This problem occasionally occurs in public water supplies.) Sand and sediment may plug the filter, restricting the flow through the media bed. Note: Well and/or pump problems affecting the operation of the filter and repairs are not covered under the warranty.

Electrical: A continuous 110 volt/60 cycle current supply is required. Make certain the current supply is uninterrupted and cannot be turned off with another switch. All electrical connections must be connected per local codes. **Surge protection is recommended with all electrical controls.**

Existing Plumbing: Condition of existing plumbing must be free from lime and iron build-up. Piping that is built-up heavily with lime and/or iron must be replaced. If piping is blocked with iron, additional equipment may be needed ahead of the filter to correct the problem.

Drain Lines: The pipe size for the drain line should be a minimum of 3/4". Backwash flow rates in excess of 7 gpm or length in excess of 2 O' require 1" drain line. Drain line must terminate with air gaps that conform to ASME A112.1.2 or ASME A112.1.3 to a code compliant receptor. Multiplex systems that operate independent of each other require individual drain lines. Under Wisconsin code drain line material must be approved water distribution piping per Wisconsin code 384.30-8.

Bypass Valves: Always provide for the installation of a bypass valve.

Caution: Water temperature is not to exceed 110°F; the filter cannot be subject to freezing conditions, or to a vacuum due to loss of pressure (such as a water main break).

FILTER SYSTEM DISINFECTION

The construction materials of your Filter System will not support bacterial growth nor will these materials contaminate a water supply. However, the normal conditions existing during shipping, storage, and installation indicate the advisability of disinfecting a system after installation, before the system is used to treat potable water. In addition, during normal use a system may become fouled with organic matter or in some cases, with bacteria from the water supply.

Therefore, every Filter System should be disinfected after installation, some will require periodic disinfection during their normal life. You have two choices for disinfection as follows:

A. SODIUM HYPOCHLORITE (household bleach, non-scented, EPA registered sanitizing agent) 5.25% SODIUM HYPOCHLORITE solutions are available under such trade names such as Clorox, Lin co, Bo Peep, White Sail and Eagle Brand Bleach. Any chemical introduced into a potable water supply must be NSF/ANSI/CAN 60 listed. If stronger solutions are used, such as those sold for commercial laundries, adjust the dosage accordingly. 1. Dosage: 2 ounces per cubic foot of filter media. 2. Add the required amount of hypochlorite to the inlet of the filter system. Press REGEN and allow the Filter System to go through a normal regeneration. Remember some filter medias should NOT be regenerated in the first 24 hours, program accordingly.

BYPASS VALVE OPERATION

Softening - Filtering

NORMAL OPERATION

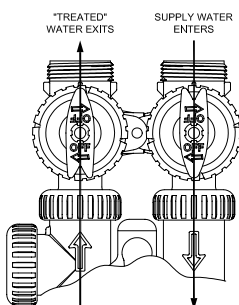

Figure 1

BYPASS OPERATION

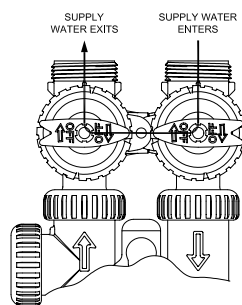

Figure 2

DIAGNOSTIC MODE

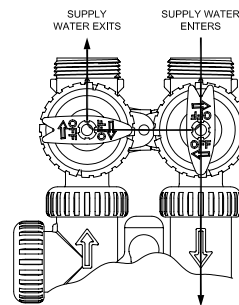

Figure 3

SHUT OFF MODE

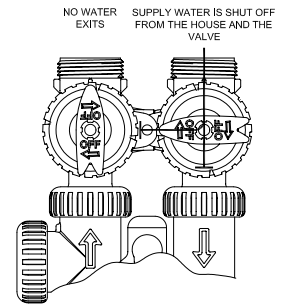

Figure 4

INSTALLATION INSTRUCTIONS

(All electrical & plumbing should be done in accordance to all local codes)

Your new Iron Curtain® Junior allows for simple installation and start up. Installation diagrams are provided to assist you. Use of these diagrams and the following procedures will ensure that the system is properly installed.

Follow all state and local plumbing and electrical codes!

- Do not use vaseline, oils, other hydrocarbon lubricants or spray silicone anywhere. A silicon lubricant may be used on black o-rings but is not necessary. **Avoid any type of lubricants, including silicone, on red or clear lip seals.**
- Do not use pipe dope or other sealants on threads. Only teflon tape may be used on threads. Teflon tape is not necessary on the nut connection or caps because of radial o-ring seals.
- **The pipe size for the drain line should be a minimum of 3/4". Backwash flow rates in excess of 10 gpm or length in excess of 20' require 1" drain line.**

1. Place the filter where you want to install it, making sure it is on a clean, level and firm base.
2. Do all necessary plumbing (Install check valve on inlet to filter, inlet to inlet, outlet to outlet and drain line to drain). The control valve, fittings and/or bypass are designed to accommodate minor plumbing misalignments but are not designed to support the weight of a system or the plumbing.
3. When assembling the installation fitting package (inlet and outlet), connect the fitting to the plumbing system first and then attach the nut, split ring and o-ring. Heat from soldering or solvent cements may damage the nut, split ring or o-ring. Solder joints should be cool and solvent cements should be set before installing the nut, split ring and o-ring. Avoid getting primer and solvent cement on any part of the

o-rings, split rings, bypass valve or control valve.

4. **A jumper ground wire should be installed between the inlet and outlet pipe whenever the metallic continuity of a water distribution piping system is interrupted. Install grounding strap on metal pipes.**
5. **Drain Lines:** The pipe size for the drain line should be a **minimum of 3/4"**. Backwash flow rates in excess of 7 gpm or length in excess of 20' require 1" drain line. Drain line must terminate with air gaps that conform to ASME A112.1.2 or ASME A112.1.3 to a code compliant receptor. Multiplex systems that operate independent of each other require individual drain lines. Under Wisconsin code drain line material must be approved water distribution piping per Wisconsin code 384.30-8.
6. When installing a filter system it is common to provide filtered water to some fixtures such as the kitchen cold faucet. This is typically done as a matter of personal preference. In rare occasions it has been noted that the customer may experience some air in the filtered water line on the morning after regeneration. It has proven to be beneficial to plumb the line for filtered-only water fixture in a downward direction before the inlet to the softener (12 inches recommended), then make a reverse turn and go upward toward the fixture. Understanding that air always rises to the highest point in a water system, and it cannot naturally flow downward. Connect inlet of filter to water system supply lines.

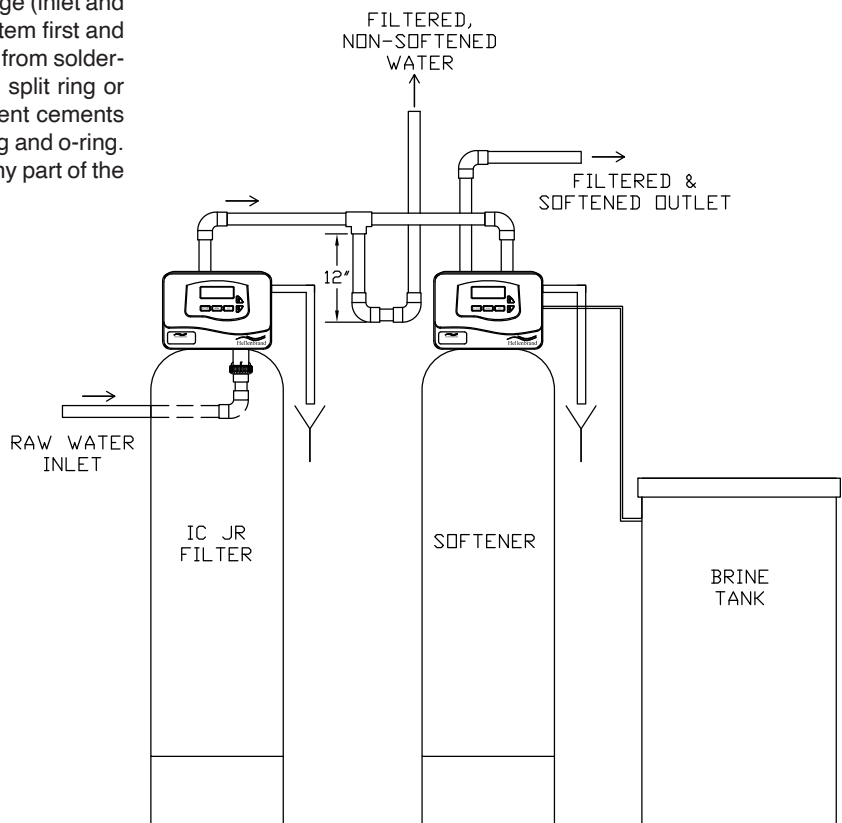
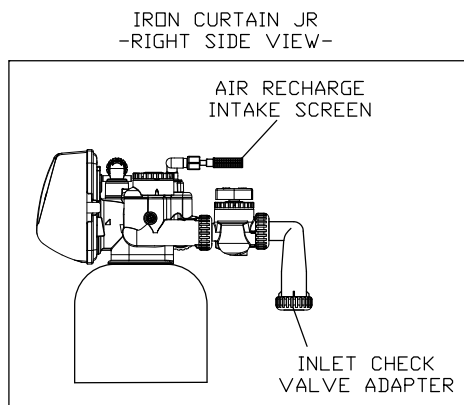

When installing an Iron Curtain Filter system it is common to provide filtered only water to some fixtures such as the kitchen cold faucet. This is typically done as a matter of personal preference. On rare occasions, the customer may experience some air in the filtered water line the morning after regeneration. It has proven beneficial to plumb the line for the filtered only water fixture in a downward direction from the inlet of the softener (12 inches recommended), then make a reverse turn and go upward toward the fixture. Any accumulated air always rises to the highest point in a water system and cannot naturally flow downward.

Iron Curtain Jr Start Up Instructions

1. Complete all plumbing connections; inlet, outlet and drain line.
2. Place bypass valve in bypass position (see page 4). Turn on main water supply and open a cold filtered faucet to flush piping of any air and/or foreign material. Run until water is clear.
3. Open inlet valve slowly until it is in fully open position. Let water run to drain until clear. Plug unit into 120V outlet and remove cover and plug transformer connection into 4-prong connection on circuit board labeled power. Valve will return to service position.
4. Initiate backwash by holding "REGEN" button down until piston movement is heard. Backwash until water at drain is clear.
5. Let regeneration proceed automatically to fast rinse and air recharge.
6. Push "Set Clock" and use UP and DN arrows to set correct time of day.

Operating Conditions

pH — The pH level of the influent water must be 7.0 or higher for iron oxidation reaction to proceed per the engineering specifications.*

Iron — This system is rated for a maximum of 3.0 ppm of ferrous (clear water) and/or ferric (red water) iron.*

Iron Bacteria — If iron bacteria are present; more frequent service may result, life of the Iron Curtain Junior system may be limited and the system may be unable to properly remove iron. **By properly controlling the iron bacteria with chlorine or other approved methods for bacterial reduction, the Iron Curtain Junior System will function properly. In some instances, continuous chlorination of the water supply may be needed.**

Hydrogen Sulfide — Sometimes referred to as "rotten egg" odor. This system is rated for a maximum of 1.0 ppm hydrogen sulfide. Hydrogen sulfide levels vary depending on barometric pressure.*

Manganese — Limit 1.0 ppm; amounts present over 1.0 ppm may gradually prevent iron removal. Note: For optimum manganese reduction, pH should be greater than 8.5.*

Organic Matter (Tannins) — The presence of organic matter such as tannins will prevent the oxidation process of converting the dissolved element, such as iron or manganese, to a

nonsoluble precipitate or solid substance. In other words, organics can tie up the iron preventing filtration. **The presence of organics such as tannins above 0.5 ppm voids any claims for this system to perform as stated above. In some applications, tannin levels below 0.5 ppm or the presence of other organics may hinder the operation of this system.***

Chlorine — The presence of chlorine in the raw water supply ahead of this system should be limited to a maximum of 1.0 ppm free chlorine residual and 0.5 ppm free chlorine or less when fed continuously.

Total Dissolved Solids (TDS) — While TDS does not directly affect iron removal, it is a good indicator of potential interference. Most waters have TDS less than 500 and generally present no problems to iron reduction. If any ion becomes excessive, it may cause failure of iron removal.

A TDS more than 500 ppm voids any claims for this system to perform as stated above.*

***For application parameters outside the specified operation conditions or additional information regarding the listed items, contact your dealer.**

Specifications

Iron Curtain Junior Models	Filter Tank Size	Media Cu. Ft	Inlet/Outlet	Max. Service Flow GPM	(1) Backwash Rate GPM
Iron Curtain JR-10	10"x54"	1.1	1"	4.0	5.3
Iron Curtain JR-12	12"x52"	1.6	1"	6.0	7.5
Iron Curtain JR-13	13"x54"	1.9	1"	7.0	10

(1) Water temps above 60° F will require a higher backwash rate. Consult factory.

BACKWASH FREQUENCY

Iron Applications

- 0.3 - 1.0 ppm Iron - Every 3rd Day
- 1.0 - 2.0 ppm Iron - Every Other Day
- 2.0 - 3.0 ppm Iron - Every Day

Hydrogen Sulfide Applications

0.1 - 1.0 ppm Hydrogen Sulfide - 100 Gallon for Air Draw Cycle, decrease as needed to initiate cycle each night.

Regeneration currently set to occur at 12:30 to minimize interference with softener regeneration.

PROGRAMMING

General Information

The control valve is the “brain” of your water filter. It consists of the valve body and powerhead with solid state microprocessor.

The display panel (see Figure 7) consists of the LCD display and five push buttons which are used in displaying and programming the water filter settings.

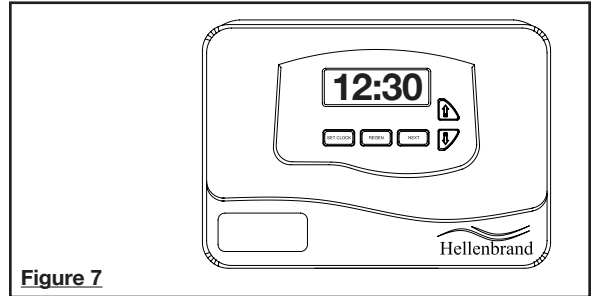

Figure 7

USER DISPLAYS/SETTINGS

General Operation

When the system is operating, one of three displays may be shown. Pressing NEXT will alternate between the displays. One of the displays is the current time of day. The second display is one of the following: days to a regen or gallons remaining. Days To A Regen is the number of days left before the system goes through a regeneration cycle. Capacity remaining is the number of gallons that will be treated before the system goes through a regeneration cycle. The third display is current flow in gal/min. The user can scroll between the displays as desired by pushing NEXT or display will scroll automatically.

When water is being treated (i.e. water is flowing through the system) the word "GPM" flashes on left side of display when other than flow rate is displayed.

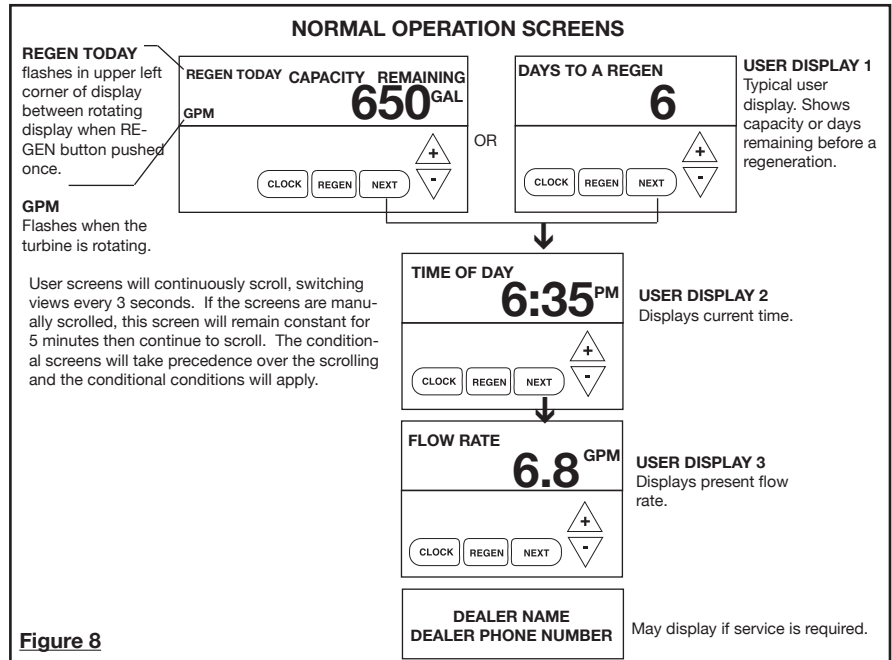

Figure 8

Regeneration Mode

Typically a system is set to regenerate at a time of low water usage. An example of a time with low water usage is when the household is asleep. If there is a demand for water when the system is regenerating, untreated water will be supplied.

When the system begins to regenerate, the display will change to include information about the step of the regeneration process and the time remaining for that step to be completed. The system runs through the steps automatically and will reset itself to provide treated water when the regeneration has been completed.

Manual Regeneration

Sometimes there is a need to regenerate the system, sooner than when the system calls for it, usually referred to as manual regeneration. There may be a period of heavy water usage because of guests or heavy laundry day.

To initiate a manual regeneration at the preset delayed regeneration time, press and release “REGEN”. The words “REGEN TODAY” will flash on the display to indicate that the system will regenerate at the preset delayed regeneration time. If you pressed the “REGEN” button in error, pressing the button again will cancel the request.

To initiate a manual regeneration immediately, press and hold the “REGEN” button for three seconds. The system will begin to regenerate immediately. The request cannot be cancelled. You must cycle all the way through the cycles to make it stop. PLEASE NOTE: This will reset the meter.

Regeneration Step #2
(shows time remaining in "Backwash" is 8:22)



Figure 11

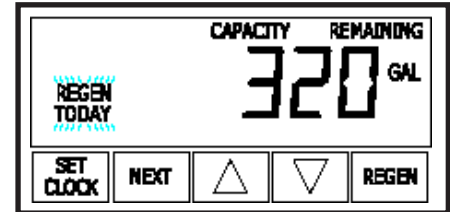

Figure 12

TABLE 4 - FILTERING REGENERATION CYCLES

No Chemical Regeneration	Factory Settings	Length of Cycle
#1 Sequence	Backwash	10 seconds
	Air Draw	10" tank - 5 minutes
		12" tank - 8 minutes
		13" tank - 13 minutes
#2 Sequence	Backwash	12 Minutes
	Rinse	6 Minutes
	Air Draw	10" tank - 5 minutes
		12" tank - 8 minutes
		13" tank - 13 minutes

WATER FILTER DISINFECTION

The materials of construction of your water filter will not support bacterial growth nor will these materials contaminate a water supply. However, the normal conditions existing during shipping, storage, and installation indicate the advisability of disinfecting a filter after installation, before the equipment is used to treat potable water. In addition, during normal use a filter may become fouled with organic matter or in some cases, with bacteria from the water supply.

Every water filter should be disinfected after installation, some will require periodic disinfection during their normal life. **Disinfection:** Disinfection methods kill most of harmful bacteria found in water which may cause illness. Disinfection methods may vary depending on what media is contained in the filter. Contact your dealer for specific instructions.

Set Time Of Day

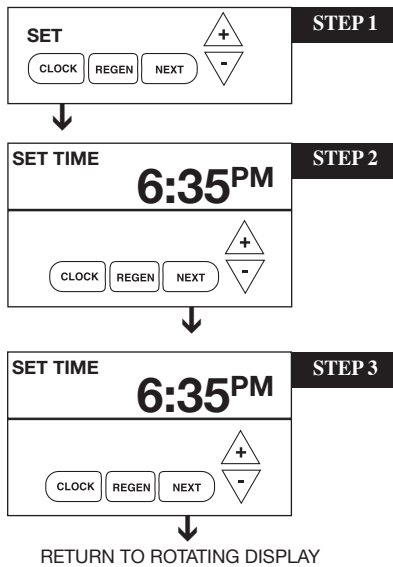

△ = ▲ Up Arrow ▽ = ▼ Down Arrow

Step 1 - Press SET CLOCK.

Step 2 - Current Time (**hour**): Set the hour of the day using ▲ or ▼ buttons. AM/PM toggles after 12. Press NEXT to go to step 3.

Step 3 - Current Time (**minutes**): Set the minutes of day using ▲ or ▼ buttons. Press NEXT to exit Set Clock. Press REGEN to return to previous step.

Power Loss - Lithium battery on circuit board provides up to 2 years of time clock backup during power outages. If the power is out when battery is depleted, only time of day needs to be reset, all other values are stored in non-volatile memory. When time of day is flashing, replace lithium coin type 2032 battery.

Battery back-up feature will be activated after 24 hours of power.

Do not forget to reset for daylight savings time.

Recommended Annual Maintenance

To be performed by dealer

- Test raw water, assure filter settings are appropriate for the application. Note and record any changes.
- Verify injector is clean and functioning.
- View head of air and determine need for cleaning inlet diffuser by running at service flow and then note difference when bypass open. If significantly different, disconnect valve from tank and clean inlet diffuser. If IRB slime or iron build-up is present, bacterial control may be required.
- Check back wash flow is proper and water supply is maintained for the duration of the backwash cycle.
- Check, clean or replace air draw check valve (at brine elbow).
- Confirm draw time setting draws air to top of bed.
- Check filter valve settings.
- Check diagnostic information to review any errors, address errors if present.
- Note and record any changes.
- Anticipated life of stack & piston is 5-7 years for standard ferric and ferrous iron applications. The presence of iron bacteria may require more frequent service.
- It is recommended to change the battery (CR2032), stock code 110038, on the control valve circuit board if it is more than two years old. This maintains time of day in the event of power loss.

PROMATE 6 IRON CURTAIN JUNIOR

Item	Description	Qty	Part #
1	Metered Control	1	104295, specify flow control
3&4	Mineral Tank Assembly		<u>Item 3 only</u> <u>Item 4 only</u>
	IC-JR 1054 Filter Tank	1	104554 D1130-52.25, 101173
	IC-JR 1252 Filter Tank	1	104561 D1130-49.25, 101173
5	Filter Media	1	109285 IC JR-10 Rebed 109286 IC JR-12 Rebed
6	Plate Distributor - (Part of Vortech Tank)		
7	Bypass Valve	1	V3006
8	Inline Check Valve Kit	1	104174 (includes 90° vertical adapter & inline check valve)
9	Air Recharge Intake Screen	1	109038
10	Internal Check Valve Assy	1	110754
11	Blocker, Air WS1 CV 1.050	1	D1047

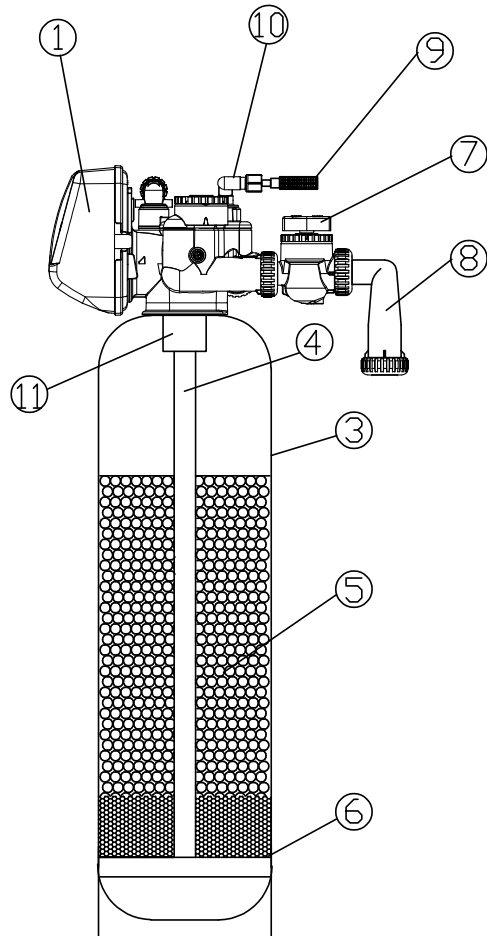

Compatible with the following regenerants or chemicals: Sodium chloride, potassium permanganate, sodium bisulfite, sodium hydroxide, hydrochloric acid, chlorine and chloramines. For specific regeneration systems, contact factory.

TROUBLE SHOOTING

PROBLEM	CAUSE	CORRECTION
1. Control valve stalled in regeneration	<ul style="list-style-type: none"> A. Motor not operating B. No electric power at outlet C. Defective transformer D. Defective PC board E. Broken drive gear or drive cap assembly F. Broken piston retainer G. Broken main or regenerant piston 	<ul style="list-style-type: none"> A. Replace Motor B. Repair outlet or use working outlet C. Should provide 12 volts when plugged into outlet, if not, replace transformer D. Replace PC board E. Replace drive gear or drive cap assembly F. Replace drive cap assembly G. Replace main or regenerant piston
2. Blank or incomplete LED display	<ul style="list-style-type: none"> A. Transformer unplugged B. No electric power at outlet C. Defective transformer D. Short in meter E. Check battery, should be greater than 3 volts F. Defective PC board 	<ul style="list-style-type: none"> A. Connect to power B. Repair outlet or use working outlet C. Should provide 12 volts when plugged into outlet, if not, replace transformer D. Unplug meter from PC board, if LED lights appropriately, replace meter assembly. E. Replace battery if less than 3 volts F. Replace PC board
3. Control does not display correct	<ul style="list-style-type: none"> A. Power outage > 2 years time of day B. Power outage < 2 years, time of day flashing, battery depleted 	<ul style="list-style-type: none"> A. Reset time of day, replace lithium coin type battery on circuit board B. Reset time of day, replace lithium coin type battery on circuit board
4. No "filtering" display when water is flowing	<ul style="list-style-type: none"> A. Bypass valve in bypass position B. Meter connection disconnected C. Restricted/stalled meter turbine D. Defective meter E. Defective PC board 	<ul style="list-style-type: none"> A. Put bypass valve in service position B. Connect meter to PC board C. Remove meter and check for rotation, clean foreign material D. Replace meter E. Replace PC board
5. Control valve regenerates at wrong time of day	<ul style="list-style-type: none"> A. Power outages B. Time of day not set correctly C. Time of regeneration incorrect D. Control valve set at "on 0" (immediate regeneration) E. Control valve set at NORMAL + on 0 	<ul style="list-style-type: none"> A. Reset control valve to correct time of day B. Reset to correct time of day C. Reset regeneration time D. Check control valve set-up procedure regeneration time option E. Check control valve set-up procedure regeneration time option

FILTER WARRANTY

INCLUDES – Iron Curtain® 2.0, Iron Curtain® Jr. and Storm Filter Systems

Hellenbrand warrants to the original consumer purchaser that the system and the parts listed below will be free from defects in material and/or workmanship from the date of the original installation for the following time periods:

For a Period of FIVE YEARS: The filter control valve electrical parts including the motor and board, control valve body, excluding internal parts.

For a Period of FIVE YEARS: The IC-2.0 Aeration Macromatic Timer.

For a Period of FIVE YEARS: The IC-2.0 aeration control body, excluding its internal parts, solenoid and air pump assemblies.

For a Period of TEN YEARS: The fiberglass aeration or mineral tanks, 6" Diameter - 13" Diameter.

For a Period of FIVE YEARS: The fiberglass aeration or mineral tanks, 14" Diameter - Up.

For a Period of ONE YEAR: The Ozone Generator.

For a Period of ONE YEAR: The entire unit system ("System").

Any parts used for replacement are warranted for the remainder of the original warranty period for the applicable part.

THIS WARRANTY IS EFFECTIVE TO THE ORIGINAL CONSUMER PURCHASER ONLY, AND ONLY FOR AS LONG AS THE SYSTEM REMAINS AT THE ORIGINAL INSTALLATION SITE. COVERAGE TERMINATES IF YOU SELL OR OTHERWISE TRANSFER THE SYSTEM OR IF THE SYSTEM IS MOVED FROM THE ORIGINAL INSTALLATION SITE.

No sales representative, distributor, agent, dealer, reseller, authorized seller or any other person or entity is authorized to make any other warranty, or modify or expand the warranty provided herein on behalf of Hellenbrand. Upon expiration of the applicable warranty period, Hellenbrand shall have no further liability related to the System/parts to which the warranty period applies, except with respect to valid warranty claims asserted during the appropriate warranty period.

If the System or any part described above becomes defective within the specified warranty period, you should notify your local authorized seller of Hellenbrand products, and arrange a time during normal business hours for the inspection of the System at the original installation site. You may also contact Hellenbrand and we will provide you with the contact information for your local authorized seller of Hellenbrand products. Hellenbrand, at its option, will repair or replace the System or any part found defective within the terms of this warranty. You are responsible for freight from our factory and any service fees charged by the local authorized seller of Hellenbrand products for installation, repair, removal, replacement, service, etc., of any System or parts. This warranty does not include any labor charges. This paragraph sets forth the exclusive remedy for any valid warranty claims against Hellenbrand.

THIS WARRANTY DOES NOT COVER defects caused by sand, sediment or bacteria fouling, accident, fire, flood, Act of God, misuse, misapplication, neglect, alteration, installation or operation contrary to Hellenbrand's printed instructions, or installation, repair or service by anyone other than Hellenbrand or an authorized seller of Hellenbrand products.

IN ADDITION, THIS WARRANTY DOES NOT COVER UNPROTECTED OUTDOOR INSTALLATIONS. This System, including all of the electrical components, must be protected against windblown dust, falling and windblown rain, freezing temperatures and the formation of ice, with an appropriate enclosure consisting of a floor, roof, walls, ventilation and heat.

As a manufacturer, we do not know the characteristics of your water supply or the purpose for which you are purchasing this system. You should be aware that the quality of water supplies may vary seasonally or over a period of time, and that your water usage rate may vary as well. Water characteristics may change considerably if this System is moved to a new location. For these reasons, Hellenbrand assumes no liability for the determination of the proper equipment necessary to meet your needs; and Hellenbrand does not authorize others to assume such obligations for Hellenbrand.

TO THE EXTENT PERMITTED BY APPLICABLE LAW, REMEDIES FOR DEFECTS OR FAILURES ARE LIMITED TO THE REMEDIES PROVIDED IN THIS WARRANTY. THERE ARE NO EXPRESS WARRANTIES OTHER THAN THOSE SET FORTH HEREIN. ANY IMPLIED WARRANTIES, INCLUDING WITHOUT LIMITATION WARRANTIES OF MERCHANTABILITY, FITNESS FOR PARTICULAR PURPOSE, NON-INFRINGEMENT, OR ANY WARRANTIES ARISING FROM COURSE OF PERFORMANCE, COURSE OF DEALING, OR FROM USAGES OF TRADE, ARE LIMITED IN DURATION TO THE APPLICABLE WARRANTY PERIOD SET FORTH ABOVE.

UNDER NO CIRCUMSTANCES SHALL HELLENBRAND BE LIABLE TO THE ORIGINAL CONSUMER PURCHASER OR TO ANY OTHER PERSON FOR ANY INCIDENTAL, INDIRECT, SPECIAL OR CONSEQUENTIAL DAMAGES OR FOR ANY OTHER LOSS, DAMAGE, OR EXPENSE OF ANY KIND, INCLUDING LOSS OF PROFITS, WHETHER ARISING OUT OF BREACH OF WARRANTY, BREACH OF CONTRACT, IN TORT OR OTHERWISE, AND REGARDLESS OF WHETHER HELLENBRAND WAS AWARE OF THE POSSIBILITY OF SUCH LOSS. THESE LIMITATIONS WILL APPLY REGARDLESS OF ANY FAILURE OF ESSENTIAL PURPOSE OF ANY LIMITED REMEDY.

Some states do not allow limitations on how long an implied warranty lasts, so the above limitations may not apply to you. Similarly, some states do not allow the exclusion or limitation of incidental or consequential damages, so the above limitation or exclusion may not apply to you. This warranty gives you specific legal rights, and you may also have other rights which vary from state to state. Hellenbrand products are not for sale or distribution into the State of California effective 8/31/18.